

VMM-1

Video Monitor Multicam 1

USER MANUAL

June 10, 2020



Imprint

Copyright

© 2020 Arnold & Richter Cine Technik GmbH & Co. Betriebs KG. All rights reserved. No portions of this document may be reproduced without prior written consent of Arnold & Richter Cine Technik GmbH & Co. Betriebs KG. Specifications are subject to change without notice. Errors, omissions, and modifications excepted.

AMIRA, ALEXA, ALEXA XT, ALEXA SXT, ALEXA LF, ALEXA Mini and ALEXA Mini LF are trademarks or registered trademarks of Arnold & Richter Cine Technik GmbH & Co. Betriebs KG. All other brands or products are trademarks or registered trademarks of their respective holders and should be treated as such.

Original version.

For Further Assistance

Arnold & Richter Cine Technik GmbH & Co. Betriebs KG
Herbert-Bayer-Str. 10
D-80807 Munich
Germany

E-mail: service@arri.com

www.arri.com/en/technical-service

Document Revision History

Document ID: D45 10005351

Version	Release	Date
v1.0	K10395	June 10, 2020

1 Contents

1	Contents.....	3
2	Disclaimer.....	4
3	Scope of Delivery and Warranty.....	5
4	Safety Guidelines.....	6
5	Monitor Layout.....	7
6	Monitor Connectors.....	9
7	Front Controls.....	10
8	OSD Keypad and Menu Operation.....	12
9	Monitor Menu.....	13
9.1	Main Menu.....	13
9.2	Options Submenu.....	15
9.3	Hotkeys and Quickmenu.....	16
9.4	Info Pages.....	17
10	Appendix.....	18
10.1	Technical Data.....	18
10.2	Connector Pin-Outs.....	19
10.3	Declaration of Conformity.....	19
10.4	Accessories.....	20
10.5	Dimensional Drawings.....	21

2 Disclaimer

Before using the products described in this manual be sure to read and understand all respective instructions.

The ARRI VMM-1 is only available to commercial customers. The customer grants by utilization that the ARRI VMM-1 or other components of the system are deployed for commercial use. Otherwise the customer has the obligation to contact ARRI preceding the utilization.

While ARRI endeavors to enhance the quality, reliability and safety of their products, customers agree and acknowledge that the possibility of defects thereof cannot be eliminated entirely. To minimize risk of damage to property or injury (including death) to persons arising from defects in the products, customers must incorporate sufficient safety measures in their work with the system and have to heed the stated canonic use.

ARRI or its subsidiaries do not assume any responsibility for incurred losses due to improper handling or configuration of the camera or other system components, due to sensor contamination, occurrence of dead or defective pixels, defective signal connections or incompatibilities with third party recording devices.

ARRI assumes no responsibility for any errors that may appear in this document. The information is subject to change without notice.

For product specification changes since this manual was published, refer to the latest publications of ARRI data sheets or data books, etc., for the most up-to-date specifications. Not all products and/or types are available in every country. Please check with an ARRI sales representative for availability and additional information.

Neither ARRI nor its subsidiaries assume any liability for infringement of patents, copyrights or other intellectual property rights of third parties by or arising from the use of ARRI products or any other liability arising from the use of such products. No license, express, implied or otherwise, is granted under any patents, copyrights or other intellectual property right of ARRI or others.

ARRI or its subsidiaries expressly exclude any liability, warranty, demand or other obligation for any claim, representation, or cause, or action, or whatsoever, express or implied, whether in contract or tort, including negligence, or incorporated in terms and conditions, whether by statute, law or otherwise. In no event shall ARRI or its subsidiaries be liable for or have a remedy for recovery of any special, direct, indirect, incidental, or consequential damages, including, but not limited to lost profits, lost savings, lost revenues or economic loss of any kind or for any claim by third party, downtime, good will, damage to or replacement of equipment or property, any cost or recovering of any material or goods associated with the assembly or use of our products, or any other damages or injury of the persons and so on or under any other legal theory.

In the case one or all of the foregoing clauses are not allowed by applicable law, the fullest extent permissible clauses by applicable law are validated.



ARRI is a registered trademark of
Arnold & Richter Cine Technik GmbH & Co Betriebs KG.

3 Scope of Delivery and Warranty

Delivery

On delivery, please check if package and content are intact. Never accept a damaged/incomplete delivery. A complete delivery includes:

- ARRI VMM-1 Monitor (K2.0023813)
- AMIRA to CCP-1 cable 0,75 m / 29 inch (K2.0008135)
- ALEXA Mini to CCP-1 cable 0,75 m / 29 inch (K2.0009336)
- VMM-1 Power Cable 0.4 m / 16 inch (K2.0037711)
- Sunshade

ADVICE

Product and packaging contain recyclable materials. Always store, ship and dispose according to local regulations.

ARRI is not liable for consequences from inadequate storage, shipment or disposal.

ATTENTION

The VMM-1 is NOT compatible with the ARRI ALEXA Mini camera.

ARRI offers an increasing variety of product bundles and additional accessories.

For details, please consult our website or your local ARRI Service Partner.

The VMM-1 is manufactured by Baytek Industriesysteme GmbH.

Leipziger Straße 4

85386 Eching

Deutschland

<https://www.baytek.de/>

Warranty

For scope of warranty, please ask your local ARRI Service Partner. ARRI is not liable for consequences from inadequate shipment, improper use or third-party products.

4 Safety Guidelines

General Safety Guidelines

- ▶ Always follow these guidelines to ensure against injury to yourself or others and damage to the system or other objects.
- ▶ Assembly and initial operation should be carried out only by staff familiar with the system.
- ▶ This safety information is in addition to the product specific operating instructions in general and must be strictly observed for safety reasons.
- ▶ Read and understand all safety and operating instructions before you operate or install the system.
- ▶ Retain all safety and operating instructions for future reference.
- ▶ Heed all warnings on the system and in the safety and operating instructions before you operate or install the system. Follow all installation and operating instructions.
- ▶ Do not use accessories or attachments that are not recommended by ARRI, as they may cause hazards and invalidate the warranty.
- ▶ Only use the tools, materials and procedures recommended in this document. For the correct use of other equipment, see the manufacturer's instructions.

ADVICE

Do not store the monitor in places where it may be subject to temperature extremes, direct sunlight, high humidity, severe vibration, or strong magnetic fields.

Do not subject the system to severe shocks.

Do not expose the LCD panel to direct sunlight, this may lead to degradation of the panel characteristics. A lightproof shade or similar should be attached when the monitor is used in such environments.

5 Monitor Layout

Monitor Front

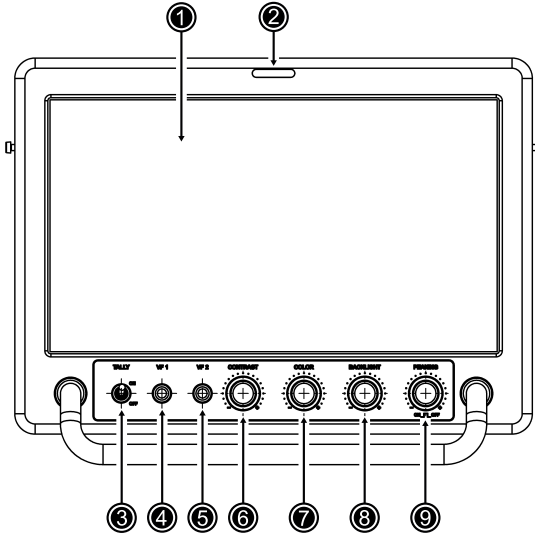

- 1 10" Display
- 2 Operator Tally LED
- 3 Tally Switch
- 4 VF 1 User Button
- 5 VF 2 User Button
- 6 CONTRAST Dial
- 7 COLOR Dial
- 8 BACKLIGHT Dial
- 9 PEAKING Dial

Monitor Top

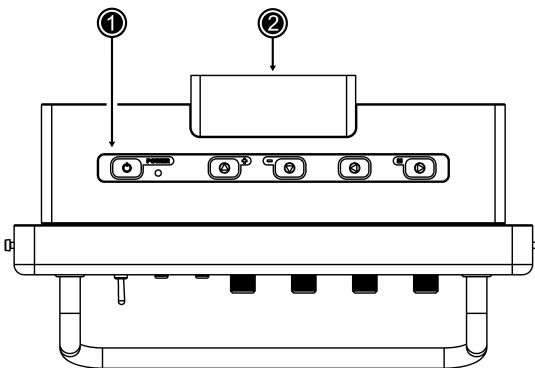

- 1 OSD Keypad
- 2 Moderator Tally LED

Monitor Bottom

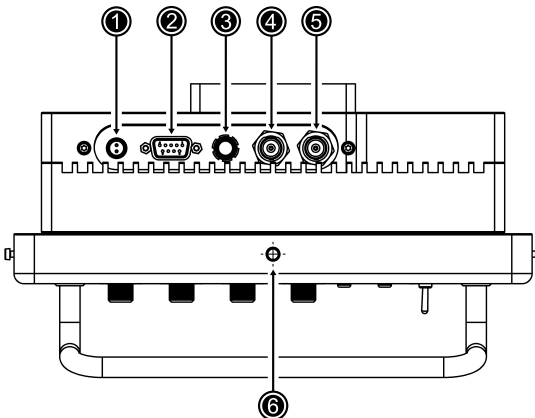

- 1 PWR Power Connector
- 2 TALLY In Connector
- 3 CAMERA Connector
- 4 SDI In Connector
- 5 SDI Loop Connector
- 6 1/4"-20 UNC camera threaded hole

Monitor Rear

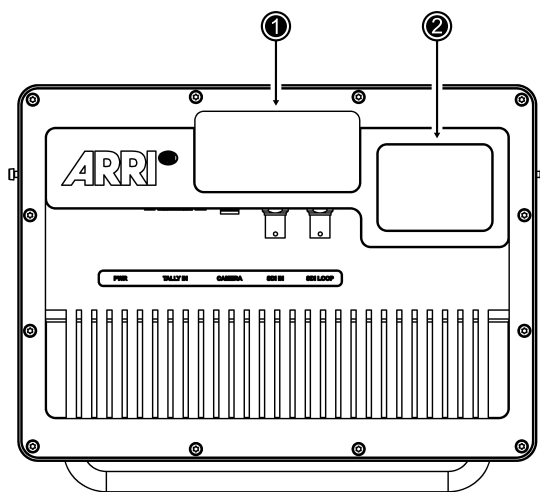

- 1 Moderator Tally LED
- 2 Camera No. Display

6 Monitor Connectors

PWR Connector (2-pin LEMO)

The PWR connector is the main power input of the VMM-1 and accepts an input voltage range from 9.0 to 32.0 V DC. Using the VMM-1 Power Cable (K2.0037711), connect the monitor to the 12 V 2-pin LEMO power output of the ARRI AMIRA.

TALLY IN Connector (DE9 Female)

Use the Tally In connector in order to activate and deactivate the red and green tally lights built into the monitor.

CAMERA Connector (16-pin ODU)

The 16-pin ODU connector transmits images as well as control data. Connect the monitor to the camera using the AMIRA to CCP-1 cable (K2.0012223).

Alternatively the monitor can be daisy-chained to the ARRI Camera Control Panel CCP-1 (K2.0008151) using the supplied ALEXA Mini to CCP-1 cable (K2.0009336).

SDI IN Connector (BNC)

The SDI In connector accepts SDI signals according to SMPTE ST 292-1:2012 and SMPTE ST 425-1:2014 (3G up to 60fps).

SDI LOOP Connector (BNC)

The SDI LOOP connector is an SDI throughput output port that outputs the signal that is present at the SDI In connector.

7 Front Controls

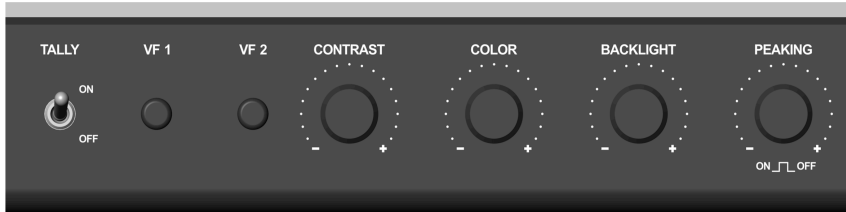

TALLY Switch

The tally switch turns the Moderator Tally LED on/off. Tally functionality itself can be configured in the camera menu. Per camera factory default, tally functionality is enabled.

1. In the camera menu, go to *Menu > Recording > Rec beeper/tally > Tally MVF-1* to ensure tally functionality is enabled.

Note: The monitor tally switch is without function if *Tally MVF-1* is disabled in the camera.

2. Use the tally switch to enable/disable the tally on the monitor.

VF 1 & 2 User Buttons

The VF 1 / VF 2 user buttons can be customized with individual camera functions.

1. In the camera menu, go to *Menu > User buttons*.
2. Select *Button VF-1* to assign a function to the VF-1 user button.
3. Select *Button VF-2* to assign a function to the VF-2 user button.

For a list of available user button functions please refer to the camera user manual.

4. Once a user button is assigned with a function, press the button to trigger its function.

CONTRAST Dial

Rotating the CONTRAST dial opens the contrast control overlay and the contrast value of the current signal input is displayed. Rotate the dial to increase or decrease the contrast in the range of -128 to 127.

COLOR Dial

Rotating the COLOR dial opens the color control overlay and the contrast value of the current signal input is displayed. Rotate the dial to adjust the saturation of the current signal input in a range of 0 to 127. With a saturation of 127, the maximum color space is displayed. With a saturation of 0, no colors are displayed.

BACKLIGHT Dial

Rotating the BACKLIGHT dial opens the backlight control overlay and the backlight value of the current signal input is displayed. Rotate the dial to adjust the backlight of the current signal input in a range of 0 to 20. Note that operability is still guaranteed with low backlighting.

PEAKING Dial

With the use of the PEAKING dial, the ARRI camera peaking can be activated and controlled via the monitor. The camera supports two peaking modes, Color Peaking (default) and Aperture Peaking. For more information please refer to the camera user manual.

1. While the peaking control overlay is closed, press or rotate the PEAKING dial to activate the peaking control overlay to display the current status of the camera peaking (on/off, strength).
2. While the peaking control overlay is closed, press the dial twice to activate/deactivate peaking or with the peaking control overlay open, press the dial once to activate/deactivate peaking.

3. With peaking activated, rotate the dial to set the peaking strength in a range of 1 to 20.

Note: Peaking adjustment is only functional when the monitor's signal source is set to Camera.

Note: If the peaking status is changed remotely in the camera, the status is only updated after reopening the control overlay or by rotating the dial.

ADVICE

The dial control overlays can only be opened when the monitor's main menu is closed and vice versa. Furthermore, a valid signal must be present at the input for operation.

If none of the four control dials is operated, the control overlay(s) close after a timeout of approx. 5 seconds and the current values are saved.

8 OSD Keypad and Menu Operation

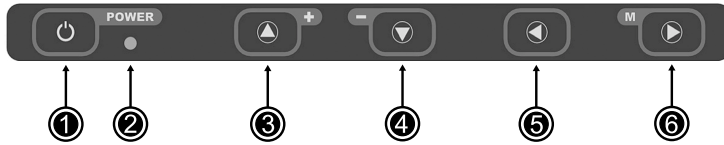

- 1 Power Button
- 2 Power LED
- 3 [UP] / + Button
- 4 [DOWN] / - Button
- 5 [LEFT] Button
- 6 [RIGHT] / M Button

Power Button and Power LED

The power button enables the monitor to be switched on/off independently of the camera.

The green power LED lights up when the monitor is active and is off when the monitor is off or the power supply was interrupted. The power LED brightness changes proportionally to the brightness level of the panel backlight. If the backlight is completely down, the LED remains off.

1. Press the power button to switch on the monitor.

Note: The monitor automatically switches on when connecting power to the PWR input. If the monitor is powered by the camera, it will automatically switch on when the camera is switched on.

2. Press and hold the power button to switch off the monitor.

OSD (On Screen Display) Buttons

The OSD buttons are used for monitor menu navigation and can be used as hotkey buttons to have quick access to frequently needed monitor settings.

Menu Operation

1. Press the [RIGHT] / M button to access the monitor menu.
2. Use the [UP] and [DOWN] buttons to scroll up or down to select the desired menu entry.
3. Press the [RIGHT] button to navigate to a submenu, to return to a higher menu level press the [LEFT] button.
4. To edit a value press the [RIGHT] button.
Then use the [RIGHT] button to increment (+) numerical values and as toggle switch for the checkbox and radiobox selections or use the [LEFT] button to decrement (-) numerical values. Press the [UP] or [DOWN] button to save changes and exit editing.
5. To exit the menu use the [LEFT] button.

Note: The OSD closes after the OSD timeout (10 seconds). Each press of a button in the OSD renews the time interval of the OSD timeout.

Lock and unlock the [RIGHT] / ([MENU]) key functions (OSD access) by pressing the [UP] and [DOWN] buttons simultaneously for 7 seconds immediately after the monitor has been switched on (Power ON).

9 Monitor Menu

9.1 Main Menu

Signal Source

The *Signal Source* menu is used to select the image input.

1. Press the [RIGHT] / M button to access the monitor menu.
2. Select menu entry *Signal Source*.

The Signal Source sub menu offers the following options:

<i>AutoScan</i>	If AutoScan is switched on, the monitor starts scanning the inputs starting with the camera input. If AutoScan is switched off, the input that was last saved is selected.
<i>Camera</i>	The monitor is set to display the image present at the camera input.
<i>SDI</i>	The monitor is set to display the image present at the SDI input.
<i>Testpattern</i>	The monitor is set to display a test pattern from the monitor's internal test pattern generator. Vertical color bars in red, green, blue and white are displayed. If you switch from the camera or SDI input to the test pattern generator input, the contrast, color saturation and brightness values are transferred from the respective signal input to the test pattern generator as standard values. Contrast, color saturation and brightness can now be changed as desired in the test pattern generator. If you then switch back to the previous signal input, the values modified with the test pattern generator are transferred to the respective input.

3. Select the desired signal source.

Position

1. Press the [RIGHT] / M button to access the monitor menu.
2. Select menu entry *Position*.

The Position sub menu offers the following options:

<i>Zoom</i>	This function zooms in on the image according to the specified numerical value. The picture is zoomed out starting from the center of the screen; an adjustable zoom window is not available. Use the OSD-keypad buttons [RIGHT] and [LEFT] to modify the zoom factor. Note: The zoom value setting is not saved and the default value is used after the monitor is repowered. The zoom value is reset to value 0 if one of the following conditions occurs: <ul style="list-style-type: none"> • Mode change • Position setting enabling the 1:1 or the Aspect Ratio checkbox • Enabling the V Mirror or the H Mirror checkbox
<i>H-Mirroring</i>	This function allows a horizontal mirroring of the screen contents. For a 180° picture rotation, please set the vertical and horizontal mirroring functions to "ON".

V-Mirroring This function allows a vertical mirroring of the screen contents. For a 180° picture rotation, please set the vertical and horizontal mirroring functions to “ON”.

Note: Settings *Autoadjust*, *Tracking*, *Phase* and *Position X/Y* are not supported.

3. Adjust the image position to your preference.

Settings

The *Settings* menu offers to adjust image parameters like contrast and brightness. Furthermore it allows you to reset the monitors setting to factory default.

1. Press the [RIGHT] / M button to access the monitor menu.
2. Select menu entry *Settings*.

The Settings sub menu offers the following options:

Brightness Use the [RIGHT] and [LEFT] buttons to adjust the numerical value. The brightness is controlled by changing the DC offset. The black level is also raised.

Contrast Use the [RIGHT] and [LEFT] buttons to adjust the numerical value. The contrast is controlled by changing the RGB signal strobe.
 Note: *Contrast* can also be changed by using the CONTRAST dial.

RGB Separate This setting allows individual analog gain adjustments of the R, G and B signal inputs. When disabled, the RGB inputs are gained equally in accordance to the *Contrast* level. When enabled, the analog gain levels for red, green and blue can be changed individually.
 Note: As soon as the CONTRAST dial is used *RGB Separate* is disabled.

LCD Backlight Brightness The *LCD Backlight Brightness* value controls the brightness of the panel LEDs. The set value should be selected in such a way that sufficient luminosity illuminates the displayed image. A value that is too low can give the impression that the panel has a defect.
 Adjust the Backlight Brightness level to your own preference. Use the [RIGHT] and [LEFT] buttons to increase or decrease the value.
 Note: *LCD Backlight Brightness* can also be changed by using the BACKLIGHT dial.

Default Values

This switch resets the monitor settings to default values:

Signal Brightness	0	Camera No.	1
Single Contrast	Off	Camera No. Active	On
Contrast	0	Camera No. Brightness	5
Single Contrast	0	Tally Moderator	10
Backlight Brightness	20	Tally Operator	1
H + V Mirror	Off	Autoscan	On
Aspect Ratio	Off	Signal Input	Camera
X, Y Position	50	VF 1 Button	Off
Zoom	0	VF 2 Button	Off
Language	English		

3. Adjust the image parameters to you preference, or reset the monitor settings to factory defaults.

Note: Settings *BL Calibration* and *ADA Function* are not supported.

9.2 Options Submenu

Language

The system language can bet set to English or German.

1. Press the [RIGHT] / M button to access the monitor menu.
2. Select *Options > Language*.
3. Set the system language to either *English* (default) or *German*.

Buttons

Hotkeys

With this function, it is possible to assign some setting parameters to the OSD-keypad buttons "UP", "DOWN" and "LEFT". With the Hotkeys, it is very simple to switch to the predefined settings without needing to navigate through the OSD-Menu.

Quickmenu

Quickmenu can be accessed by pressing the [BACK] button.

Camera Number

The *Camera Number* submenu offers to configure the 7-segment camera number display on the monitor rear.

1. Press the [RIGHT] / M button to access the monitor menu.
2. Select *Options > Camera Number*.

The *Camera Number* submenu offers the following options:

Camera No. Active

Set to display the camera number on the camera number display on the monitor rear.

Camera No.

Set the camera number to be displayed on the camera number display on the monitor rear in a range of 0 to 19.

Brightness Set the brightness of the camera number display on the monitor rear in a range of 0 to 20. If the brightness is set to 0, the display is switched off.

3. Configure the camera number display to your preference.

Tally LED

The *Tally LED* submenu offers to configure the brightness for the moderator tally LED on the monitor rear and the operator tally LED on the monitor front.

1. Press the [RIGHT] / M button to access the monitor menu.
2. Select *Options > Tally LED*.

The *Tally LED* submenu offers the following options:

Moderator Set the brightness of the moderator tally LED on the monitor rear in a range from 0 to 20. With a brightness of 0, the moderator tally LED is switched off.

Operator Set the brightness of the operator tally LED on the monitor front in a range from 0 to 20. With a brightness of 0, the operator tally LED is switched off.

3. Configure the tally LEDs to your preference.

Save Settings

All parameters which can be adjusted will be saved to memory.

1. Press the [RIGHT] / M button to access the monitor menu.
2. Select *Options > Save settings*.
3. Press the [RIGHT] key to commit settings to memory.

9.3 Hotkeys and Quickmenu

Hotkeys

With the Hotkeys function, monitor setups can be saved to the OSD-keypad buttons [UP] / +, [DOWN] / - and [LEFT]. This allows to quickly switch to or between predefined setups, without the need to change single settings in the monitor menu.

The following settings are included in the setup:

- Signal Source
- Scaling Mode (1:1 Apect or Full)
- Horizontal Mirroring
- Vertical Mirroring
- Brightness (Signal)
- Contrast (Signal)
- R/G/B Contrast
- LCD Backlight Brightness
- Operator Tally LED Brightness
- Moderator Tally LED Brightness
- Camera Number
- Camera Number Brightness

To save a setup to a hotkey

1. Press the [RIGHT] / M button to access the monitor menu.
2. Set *Options > Buttons to Hotkeys*.
3. Adjust the settings listed above to your preference.
4. Select menu entry *Hotkeys* and select the button you want to save the setup to, then press the [RIGHT] / M button to save.
5. To have this hotkey settings available after power ON/OFF sequences, it is necessary to save the actual OSD status while using „Save settings” under the “Option Menu”.

Quickmenu

The Quickmenu provides convenient access to control common monitor settings.

- **Backlight Brightness:** The brightness value can be adjusted using the [UP] or [DOWN] buttons. The menu item is automatically closed after approximately 15 seconds.

9.4 Info Pages

Input Info

The Input Info window provides information on the selected input signal, including the maximum image refresh rates (vertical frequency).

Service Info

The Service window shows the type of BayView AVD10 converter card in use. The information is useful for eventual Firmware updates (Software Revision) and for service requests (Serial No. and Product code).

Manufacturer Info

The Manufacturer Info window displays Manufacturer details.

10 Appendix

10.1 Technical Data

LCD Type	Active Matrix Liquid Crystal Display (AM-LCD) Amorphous silicon TFT (Thin Film Transistor) LED Backlight
Aspect Ratio	16:9
Active Screen Size	220.32 x 123.93 mm / 16.063 x 12.047" Ø 508 mm / 20.1"
Screen Resolution	1920 x 1080 pixel
Pixel Arrangement	B+G+R vertical stripe
Pixel Pitch	0.11475 x 0.11475 mm / 0.0045" x 0.0045"
Pixel Density	221 ppi
Screen Luminance	300 cd/m ² (max.) Backlight Dimming: 100 to 0%
Luminance Uniformity	White non-uniformity <= 30%
Color Depth	16 Mio. colors
Response Time	T _{on} + T _{off} (10% to 90% to 10%) 25 ms (typical)
Viewing Angle	Typical viewing angle CR >= 10:1 Horizontal ±85° Vertical ±85°
Contrast Ratio	1000:1 (typical) in dark environment (at optimum viewing angle)
Power Input	1x LEMO 2-pin (9.0 - 32.0 V DC)
Measurements (HxWxL)	200 x 255 x 144 mm / 7.87 x 10.04 x 5.67" (without Parasol)
Weight	~ 2.2 kg / ~ 4.85 lbs (without Parasol)
Operating Temperature	-20° C to +50° C / -4° F to +122° F @ 5% to 95% relative humidity, non condensing at 38° C wet bulb temperature
Vibration	MIL-STD 810 10-57Hz / 0.076mm 57-500Hz / 9.8m/s ² (BTM)
Shock	MIL-STD 810 ± 10G/11ms half sine (BTM)
EMI / EMC	CE / FCC

10.2 Connector Pin-Outs

Note: Pin-outs appear as seen by the user.

PWR

Connector ID: LEMO EEG.0B.302.CLN.A365

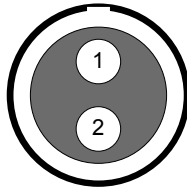

- 1 GND
- 2 PWR

TALLY IN

Connector ID: DE9 Female

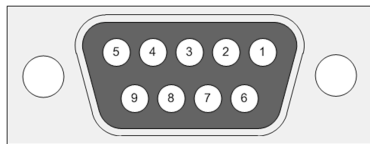

- 1 Tally RED
- 2 RxD (Service)
- 3 TxD (Service)
- 4 N.C.
- 5 GND
- 6 GND
- 7 Tally GREEN
- 8 GND
- 9 N.C.

10.3 Declaration of Conformity

FCC Compliance Statement

Class A Statement: This equipment has been tested and found to comply with the limits for a Class A digital device, pursuant to part 15 of the FCC Rules. These limits are designed to provide reasonable protection against harmful interference when the equipment is operated in a commercial environment. This equipment generates, uses, and can radiate radio frequency energy and, if not installed and used in accordance with the instruction manual, may cause harmful interference to radio communications. Operation of this equipment in a residential area is likely to cause harmful interference in which case the user will be required to correct the interference at his own expense.

EU Declaration of Conformity

The designated product conforms to the specifications of the following European directives:

- 1 Directive 2014/30/EU of the European Parliament and of the Council of 26 February 2014 on the harmonisation of the laws of the Member States relating to electromagnetic compatibility - OJ L 96, 29.3.2014, p. 79–106
- 2 Directive 2011/65/EU of the European Parliament and the Council of 8 June 2011 on the restriction of the use of certain hazardous substances in electrical and electronic equipment - OJ L 174, 1 July 2011, p. 88–110

The compliance with the requirements of the European Directives was proved by the application of the following standards:

- ▶ Essential Requirements regarding No 1: EN 55032: 2012; EN 55024: 2010
- ▶ Essential Requirements regarding No 2: EN 50581: 2012

10.4 Accessories

Mounting Option

The VMM-1 can be mounted to the camera using the ARRI Monitor Yoke Support MYS-1 (sold separately).

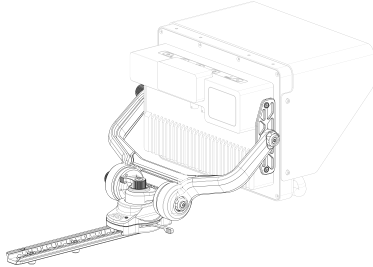

Monitor Yoke Support MYS-1 (K2.0037636)

The Monitor Yoke Support MYS-1 is designed specifically around the ARRI VMM-1 multicam monitor. It offers four points of adjustment accessible to the camera operator as well as a counterbalance system to support the weight of the monitor when it is being repositioned.

The monitor with its yoke support attached can be quickly removed from the main camera rig by sliding the monitor and yoke assembly out of the dovetail mount attached to the camera. The dovetail mount can be attached to a camera with 2x 3/8" threads facing up (e.g. ARRI AMIRA handle).

Please contact your local ARRI sales representative about product availability.

10.5 Dimensional Drawings

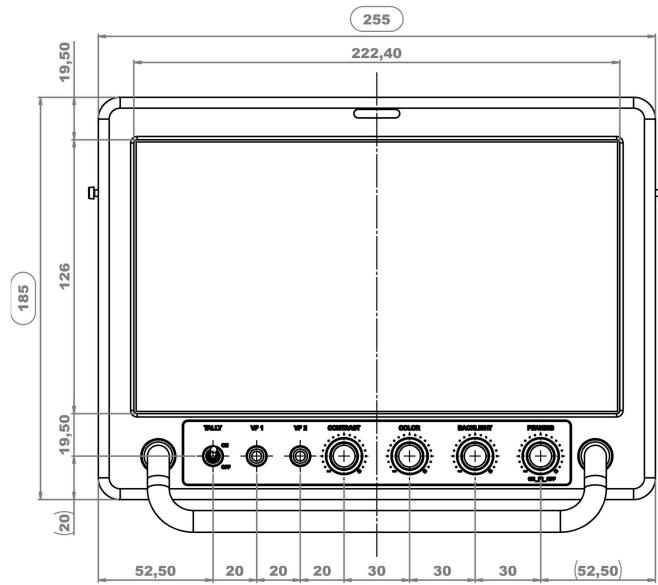

FRONT VIEW

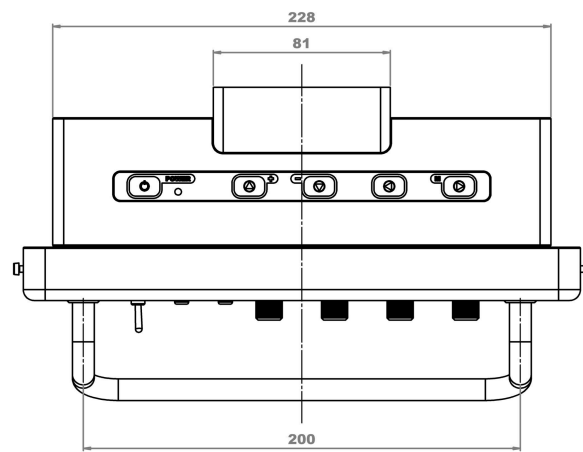

TOP VIEW

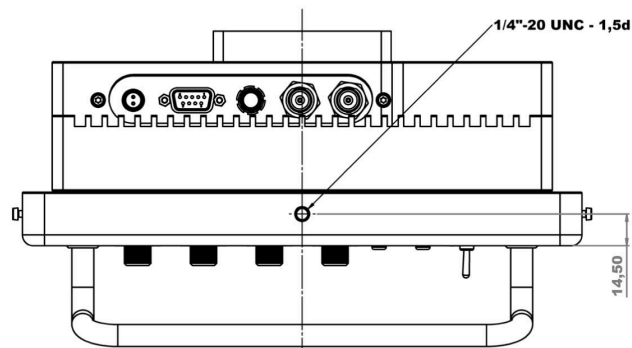

BOTTOM VIEW

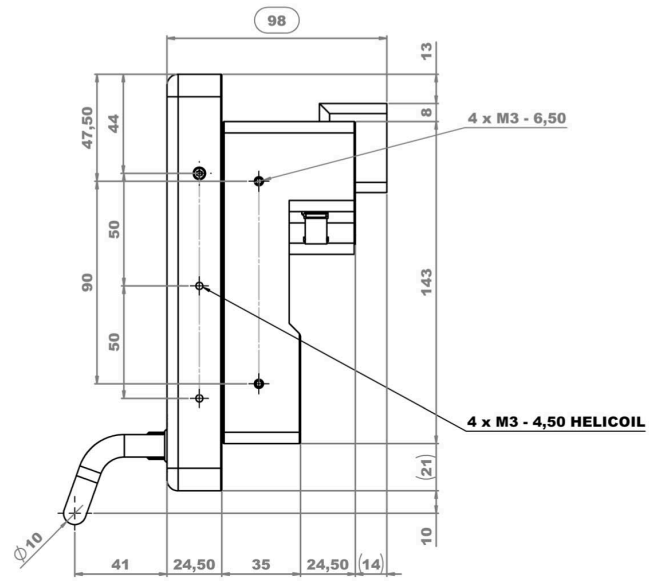

SIDE VIEW

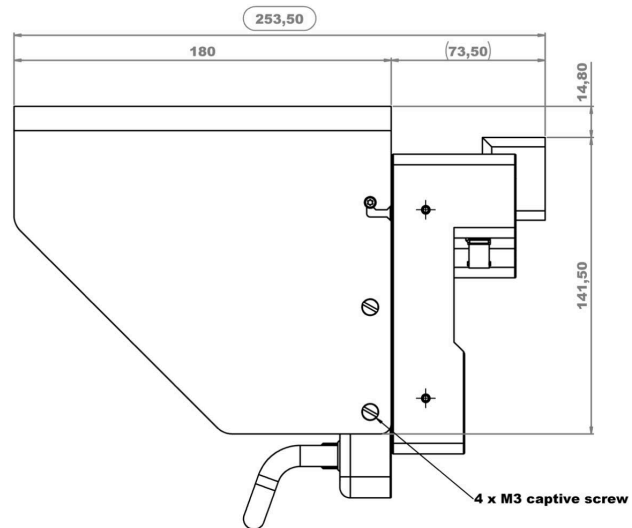

SIDE VIEW WITH PARASOL

All measurements in mm.